

Rizvi College of Arts, Science and Commerce

BLOCK DIAGRAM OF INTEL 8085

Zameer Hasan Shaikh

Department of Computer Science

Introduction to 8085

- Introduced in 1977.
- It is 8-bit MP.
- It is a 40 pin dual-in-line chip.
- It uses a single +5V supply for its operations.
- Its clock speed is about 3MHz.

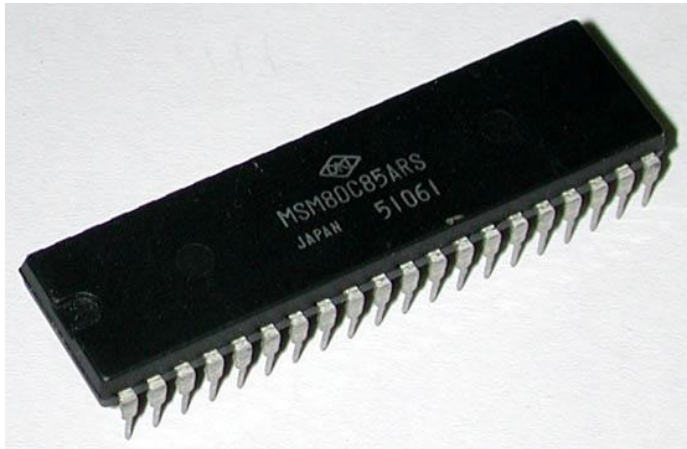

Block Diagram of 8085

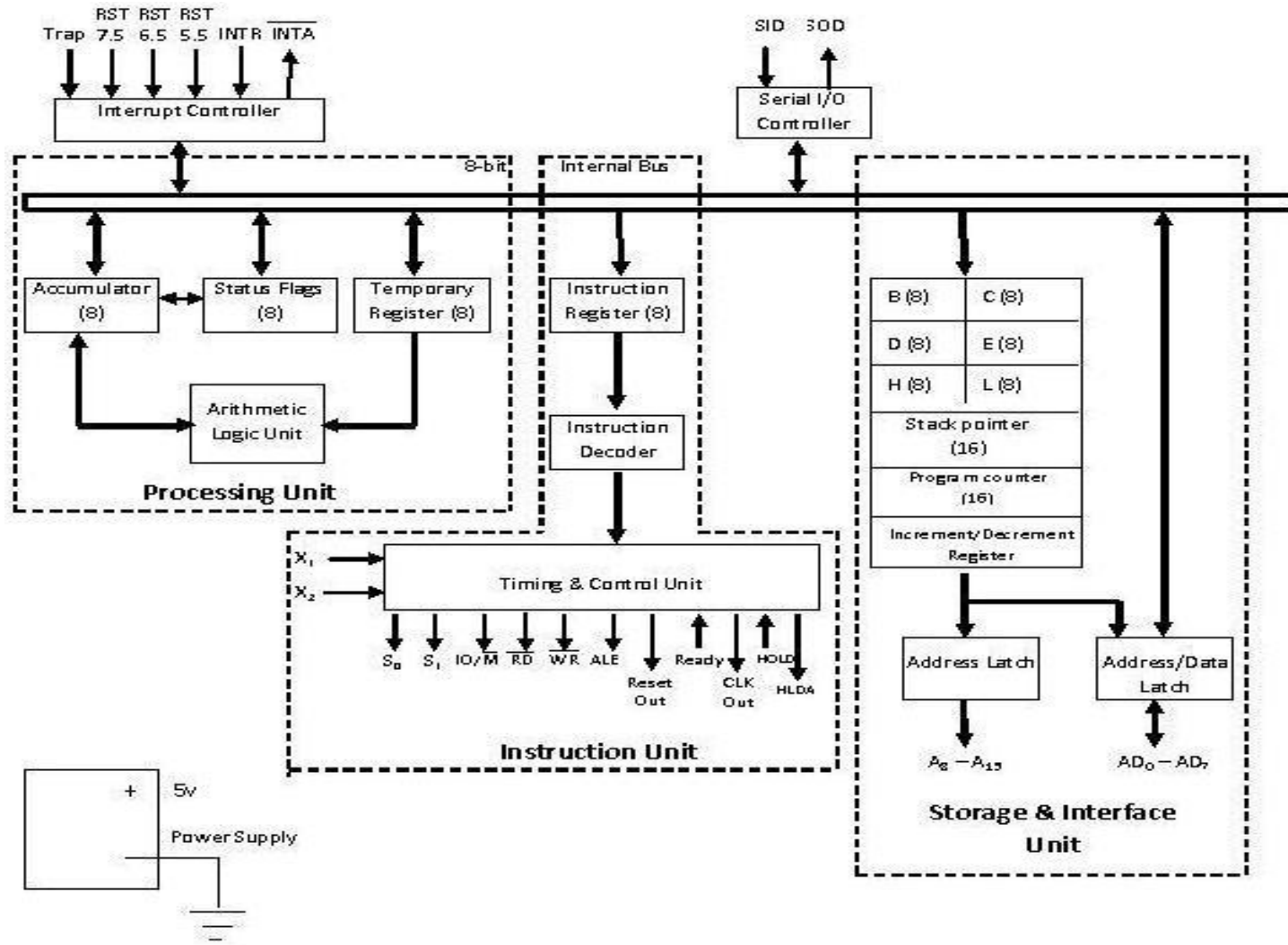

Three Units of 8085

- Processing Unit
- Instruction Unit
- Storage and Interface Unit

Processing Unit

- Arithmetic and Logic Unit
- Accumulator
- Status Flags
- Temporary Register

Instruction Unit

- Instruction Register
- Instruction Decoder
- Timing and Control Unit

Storage and Interface Unit

- General Purpose Registers
- Stack Pointer
- Program Counter
- Increment/Decrement Register
- Address Latch
- Address/Data Latch

Three Other Units

- Interrupt Controller
- Serial I/O Controller
- Power Supply

Accumulator

- It is the main register of microprocessor.
- It is also called register 'A'.
- It is an 8-bit register.
- It is used in the arithmetic and logic operations.
- It always contains one of the operands on which arithmetic/logic has to be performed.
- After the arithmetic/logic operation, the contents of accumulator are replaced by the result.

Arithmetic & Logic Unit (ALU)

- It performs various arithmetic and logic operations.
- The data is available in accumulator and temporary/general purpose registers.
- **Arithmetic Operations:**
 - Addition, Subtraction, Increment, Decrement etc.
- **Logic Operations:**
 - AND, OR, X-OR, Complement etc.

Temporary Register

- It is an 8-bit register.
- It is used to store temporary 8-bit operand from general purpose register.
- It is also used to store intermediate results.

Status Flags

- Status Flags are set of flip-flops which are used to check the status of Accumulator after the operation is performed.

D ₇	D ₆	D ₅	D ₄	D ₃	D ₂	D ₁	D ₀
S	Z	X*	AC	X*	P	X*	CY

X* = don't care condition

Status Flags

- S = Sign Flag
- Z = Zero Flag
- AC = Auxiliary Carry Flag
- P = Parity Flag
- CY = Carry Flag

Status Flags

- **Sign Flag (S):**
 - It tells the sign of result stored in Accumulator after the operation is performed.
 - If result is $-ve$, sign flag is set (1).
 - If result is $+ve$, sign flag is reset (0).

Status Flags

- **Zero Flag (Z):**
 - It tells whether the result stored in Accumulator is zero or not after the operation is performed.
 - If result is zero, zero flag is set (1).
 - If result is not zero, zero flag is reset (0).

Status Flags

- **Auxiliary Carry Flag (AC):**
 - It is used in BCD operations.
 - When there is carry in BCD addition, we add 0110 (6) to the result.
 - If there is carry in BCD addition, auxiliary carry is set (1).
 - If there is no carry, auxiliary carry is reset (0).

Status Flags

- **Parity Flag (P):**
 - It tells the parity of data stored in Accumulator.
 - If parity is even, parity flag is set (1).
 - If parity is odd, parity flag is reset (0).

Program Status Word (PSW)

- The contents of Accumulator and Status Flags clubbed together is known as Program Status Word (PSW).
- It is a 16-bit word.

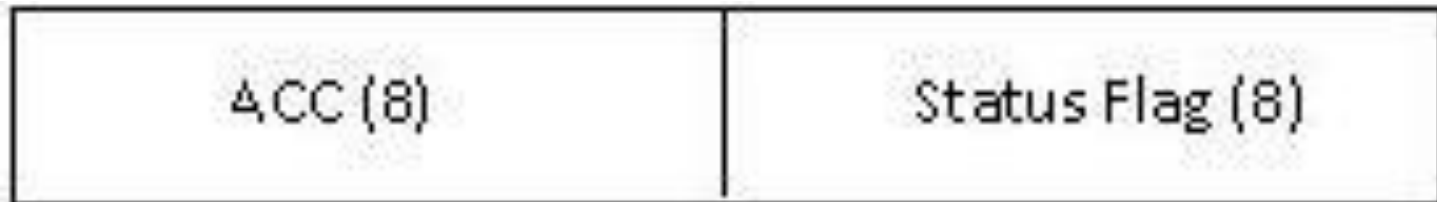

Instruction Register

- It is used to hold the current instruction which the microprocessor is about to execute.
- It is an 8-bit register.

Instruction Decoder

- It interprets the instruction stored in instruction register.
- It generates various machine cycles depending upon the instruction.
- The machine cycles are then given to the Timing and Control Unit.

Timing and Control Unit

- It controls all the operations of microprocessor and peripheral devices.
- Depending upon the machine cycles received from Instruction Decoder, it generates 12 control signals:
 - S_0 and S_1 (Status Signals).
 - ALE (Address Latch Enable).

Timing and Control Unit

- $\overline{\text{RD}}$ (Read, active low).
- $\overline{\text{WR}}$ (Write, active low).
- $\overline{\text{IO/M}}$ (Input-Output/Memory).
- READY
- $\overline{\text{RESET IN}}$
- RESET OUT
- CLK OUT
- HOLD and HLDA

General Purpose Registers

- There are 6 general purpose registers, namely B, C, D, E, H, L.
- Each of the them is 8-bit register.
- They are used to hold data and results.
- To hold 16-bit data, combination of two 8-bit registers can be used.
- This combination is known as *Register Pair*.
- The valid register pairs are:
 - B – C, D – E, H – L.

Program Counter

- It is used to hold the address of next instruction to be executed.
- It is a 16-bit register.
- The microprocessor increments the value of Program Counter after the execution of the current instruction, so that, it always points to the next instruction.

Stack Pointer

- It holds the address of top most item in the stack.
- It is also 16-bit register.
- Any portion of memory can be used as stack.

Increment/Decrement Register

- This register is used to increment or decrement the value of Stack Pointer.
- During PUSH operation, the value of Stack Pointer is incremented.
- During POP operation, the value of Stack Pointer is decremented.

Address Latch

- It is group of 8 buffers.
- The upper-byte of 16-bit address is stored in this latch.
- And then it is made available to the peripheral devices.

Address/Data Latch

- The lower-byte of address and 8-bit of data are multiplexed.
- It holds either lower-byte of address or 8-bits of data.
- This is decided by ALE (Address Latch Enable) signal.
- If $ALE = 1$ then
 - Address/Data Latch contains lower-byte of address.
- If $ALE = 0$ then
 - It contains 8-bit data.

Serial I/O Controller

- It is used to convert serial data into parallel and parallel data into serial.
- Microprocessor works with 8-bit parallel data.
- Serial I/O devices works with serial transfer of data.
- Therefore, this unit is the interface between microprocessor and serial I/O devices.

Interrupt Controller

- It is used to handle the interrupts.
- There are 5 interrupt signals in 8085:
 - TRAP
 - RST 7.5
 - RST 6.5
 - RST 5.5
 - INTR

Interrupt Controller

- Interrupt controller receives these interrupts according to their priority and applies them to the microprocessor.
- There is one outgoing signal INTA which is called Interrupt Acknowledge.

Power Supply

- This unit provides +5V power supply to the microprocessor.
- The microprocessor needs +5V power supply for its operation.